

PCL-M10

Industrial Accelerometer

NEW



CE FCC

Unit: mm

Specifications

	Item	English	SI
Performance	Sensitivity	±80 mV/g	±8.16 mV/(m/s ²)
	Sensitivity Drift	±5 % @ 32~128 °F	±5 % @ 0~60 °C
	Linearity	±0.1 %	±0.1 %
	Cross Axis Sensitivity	±1 % (X-Y) & (X-Z)	±1 % (X-Y) & (X-Z)
	Measurement Range	±50 g peak	±40.5m/s ² peak
	Frequency Range	1~10kHz	1~10kHz
	Frequency Response	11 KHz @-3dB Bandwidth	11 KHz @-3dB Bandwidth
Electrical	Excitation Voltage	+16~28 V _{DC}	+16~28 V _{DC}
	Supply Current	typical : 15 mA maximum: 30 mA	typical : 15 mA maximum: 30 mA
	Output Current	0 ~ 20 mA	0 ~ 20 mA
	Output Offset	±10 %	±10 %
	Load	maximum: 500 Ω (with WISE-750)	maximum: 500 Ω (with WISE-750)
General	Dimension	1.18 x 1.18 x 0.55 inch	30 x 30 x 14 mm
	Weight	3oz	85g
	Cable Length*	9.84 ft	3m
	Operation Temperature	32~158 °F	0~70 °C
	Certification	CE, FCC	

*Standard length is 3m, customized length is available.

Dimensions

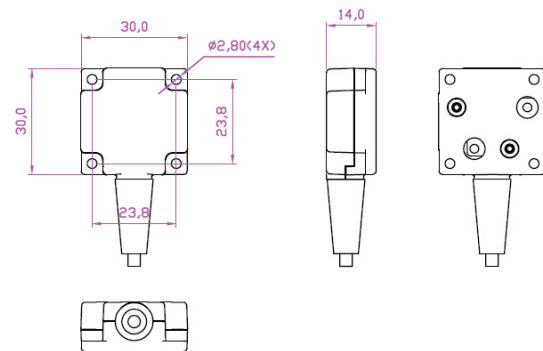

Sensor Mounting

1. Direct Mounting

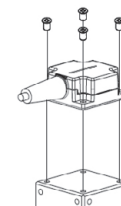

2. Mounting with adaptor and magnet plate

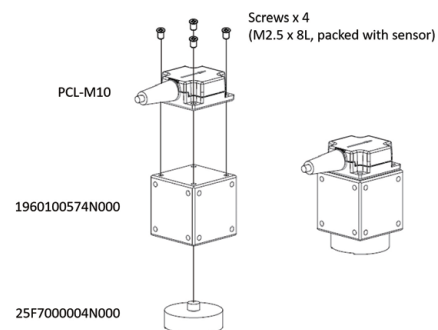

Ordering Information

Part Number	Description
PCL-M10-3E	Industrial Accelerometer, 80mV/g, 3m

Optional Accessories

Part Number	Description
25F7000004N000	Magnet D30XH9mm
1960100574N000	Adaptor for PCL-M10